

Service Facts

Single Packaged Cooling/Electric Heat

4TCA4060C1000A

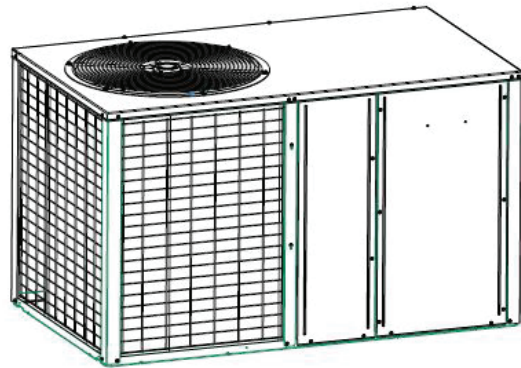

Note: "Graphics in this document are for representation only. Actual model may differ in appearance."

▲ SAFETY WARNING

Only qualified personnel should install and service the equipment. The installation, starting up, and servicing of heating, ventilating, and air-conditioning equipment can be hazardous and requires specific knowledge and training. Improperly installed, adjusted or altered equipment by an unqualified person could result in death or serious injury. When working on the equipment, observe all precautions in the literature and on the tags, stickers, and labels that are attached to the equipment.

SAFETY SECTION

Important — This document contains a wiring diagram, a parts list, and service information. This is customer property and is to remain with this unit. Please return to service information pack upon completion of work.

⚠ WARNING

HAZARDOUS VOLTAGE!

Failure to follow this Warning could result in property damage, severe personal injury, or death.

Disconnect all electric power, including remote disconnects before servicing. Follow proper lockout/tagout procedures to ensure the power cannot be inadvertently energized.

⚠ WARNING

SAFETY AND ELECTRICAL HAZARD!

Failure to follow this Warning could result in property damage, severe personal injury, or death.

These servicing instructions are for use by qualified personnel only. To reduce the risk of electrical shock, do not perform any servicing other than that contained in these operating instructions unless you are qualified to do so.

⚠ CAUTION

GROUNDING REQUIRED!

Failure to inspect or use proper service tools may result in equipment damage or personal injury. Reconnect all grounding devices. All parts of this product that are capable of conducting electrical current are grounded. If grounding wires, screws, straps, clips, nuts, or washers used to complete a path to ground are removed for service, they must be returned to their original position and properly fastened.

⚠ WARNING

UNIT CONTAINS R-410A REFRIGERANT!

Failure to use proper service tools may result in equipment damage or personal injury.

R-410A operating pressure exceeds the limit of R-22. Proper service equipment is required. Service using only R-410A Refrigerant and approved POE compressor oil.

⚠ WARNING

SAFETY HAZARD!

Operating the unit without the access panels properly installed may result in severe personal injury or death.

Do not operate the unit without the evaporator fan access panel or evaporator coil access panel in place.

⚠ WARNING

WARNING!

This product can expose you to chemicals including lead, which are known to the State of California to cause cancer and birth defects or other reproductive harm. For more information go to www.P65Warnings.ca.gov.

Important: Wear appropriate gloves, arm sleeve protectors and eye protection when servicing or maintaining this equipment.

Important: Air filters and media wheels or plates shall meet the test requirements in UL 900.

Product Specifications

MODEL	4TCA4060C1000A
RATED Volts/PH/Hz	208-230 / 1 / 60
Performance Cooling BTUH ^(a)	57000
Indoor Airflow (CFM)	1680
Power Input (KW)	4.93
EER2/SEER2 (BTU/Watt-Hr.) ^(b)	10.6 / 13.4
Sound Power Rating [dB(A)] ^(c)	78
POWER CONN. – V/Ph/Hz	208-230 / 1 / 60
Min. Cir. Ampacity ^(d)	38
Max. Overcurrent Protection	60
COMPRESSOR	SCROLL
Volts/Ph/Hz	208-230 / 1 / 60
R.L. Amps – L.R. Amps	24.4 / 144
OUTDOOR COIL – TYPE	MCHE
Rows/F.P.I	1 / 23
Face Area (sq. ft.)	14.85
Tube Size (in.)	1
INDOOR COIL – TYPE	PLATE FIN
Rows/F.P.I	4 / 16
Face Area (sq. ft.)	5.4
Tube Size (in.)	5/16
Refrigeration Control	EXPANSION VALVE
Drain Conn. Size (in.)	3/4 MALE NPT
OUTDOOR FAN – TYPE	PROPELLER
DIA. (IN.)	23
DRIVE/NO. SPEEDS	DIRECT / 1
CFM @ 0.0 in. w.g. ^(e)	3785
Motor – HP/R.P.M	1/4 / 1075

Volts/Ph/Hz	200-230 / 1 / 60
F.L. Amps/L.R Amps	1.28 FLA
INDOOR FAN – TYPE	CENTRIFUGAL
Dia. x Width (in.)	11 X 11
Drive/No. Speeds	DIRECT / 3
CFM @ 0.0 in. w.g. ^(f)	SEE FAN PERF TABLE
Motor – HP/R.P.M.	1 / VARIABLE
Volts/Ph/Hz	208-230 / 1 / 60
F.L. Amps	6.7
FILTER / FURNISHED	NO
Type Recommended	THROWAWAY
Recmd. Face Area (sq. ft) ^(g)	5.3
REFRIGERANT	R-410A
Charge (lbs.)	4.77
CHARGING SPECIFICATIONS	
Subcooling	10°
DIMENSIONS	H X W X L
Crated (in.)	36.5 X 62.5 X 45.9
WEIGHT	
Shipping (lbs.) / Net (lbs.)	551 / 521

^(a) Rated in accordance with AHRI Standard 210/240.

^(b) Rated in accordance with D.O.E. test procedure.

^(c) Sound Power values are not adjusted for AHRI 270-95 tonal corrections.

^(d) Calculated in accordance with currently prevailing Nat'l Electrical Code.

^(e) Standard Air – Dry Coil – Outdoor.

^(f) Standard Air – Dry Coil – Indoor

^(g) Filters must be installed in return air stream. Square footages listed are based on 300 f.p.m. face velocity. If permanent filters are used size per manufacturer's recommendation with a clean resistance of 0.05" W.C.

Pressure Curves

Figure 1. 4TCA4060C1

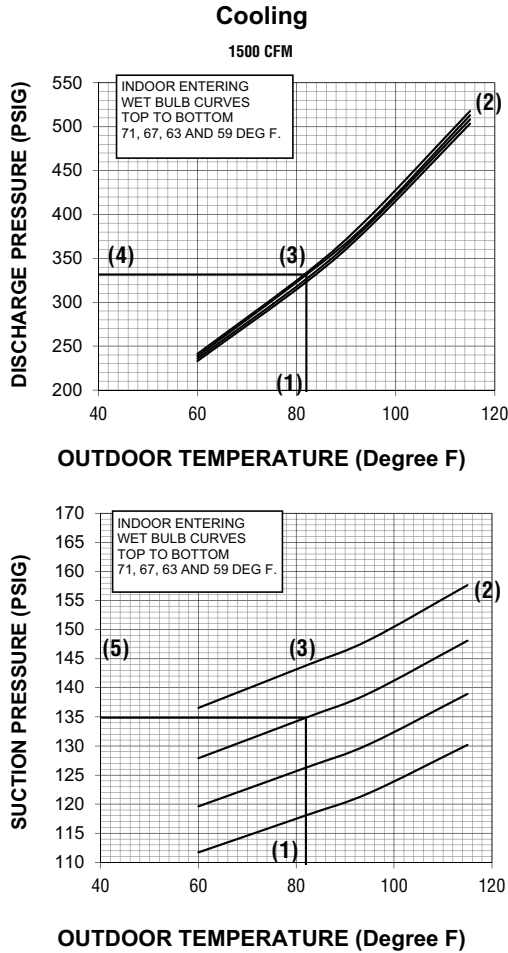

COOLING PERFORMANCE CAN BE CHECKED WHEN THE OUTDOOR TEMP IS ABOVE 65 DEG F.
 TO CHECK COOLING PERFORMANCE, SELECT THE PROPER INDOOR CFM, ALLOW PRESSURES TO STABILIZE. MEASURE INDOOR WET BULB TEMPERATURE, OUTDOOR TEMPERATURE, DISCHARGE AND SUCTION PRESSURES. ON THE PLOTS LOCATE OUTDOOR TEMPERATURE (1); LOCATE INDOOR WET BULB (2); FIND INTERSECTION OF OD TEMP. & ID W.B. (3); READ DISCHARGE OR SUCTION PRESSURE IN LEFT COLUMN (4).

- EXAMPLE: (1) OUTDOOR TEMP. 82 F.
 (2) INDOOR WET BULB 67 F.
 (3) AT INTERSECTION
 (4) DISCHARGE PRESSURE @ 1500 CFM CFM IS 332 PSIG.
 (5) SUCTION PRESSURE @ 1500 CFM CFM IS 135 PSIG.

ACTUAL:
 DISCHARGE PRESSURE SHOULD BE +/- 10 PSI OF CHART
 SUCTION PRESSURE SHOULD BE +/- 3 PSIG OF CHART

DWG.NO. 4TCA4060C1

Sequence of Operation

General

Operation of the system cooling (and optional heating) cycles is controlled by the comfort control. Once the comfort control is set to either **HEAT** or **COOL**, unit operation is automatic. The optional automatic changeover control, when set to **AUTO**, automatically changes to heat or cool with sufficient room temperature change.

The fan can be set to **ON**, causing continuous evaporator (indoor) fan operation or set to **AUTO** causing fan operation to coincide with heating or cooling run cycles. Continuous fan mode during cooling operation may not be appropriate in humid climates. If the indoor air exceeds 60% relative humidity or simply feels uncomfortably humid, it is recommended that the fan only be used in the **AUTO** mode.

Cooling Mode

With the comfort control set to **COOL** and the fan set to **AUTO**, the compressor contactor (CC) and the indoor fan motor (IDM) are energized.

The energized compressor contactor (CC) completes the circuit to the compressor (CPR) and a secondary circuit to the outdoor fan motor (ODM). If the

compressor safety controls are closed, the compressor (CPR) will operate with the outdoor fan motor (ODM). The indoor fan motor (IDM) will operate. The comfort control will continue to cycle the compressor and fans to maintain the desired temperature.

With the fan set to **ON**, the indoor fan motor (IDM) will continue to run regardless of compressor and condenser fan operation.

Heating Mode

Heating mode uses electric heaters, which are installed separately. Refer to the Supplemental Electric Heaters Installer's Guide for additional information.

On a call for heat, power from the comfort control is received at "W1", which energizes the "AH" contactor coil. The "AH" contactor closes powering the heater, provided all element limits are closed. If two stages of heat are provided and additional heat is required, the comfort control's second stage "W2" circuit is energized powering the "BH" contactor coil.

Note: *The indoor comfort control must be configured to provide a "G" signal to energize the indoor fan relay (F) during the heating mode. The heater control circuit will not be energized unless the indoor fan relay (F) is energized.*

Charging in Cooling above 55°F OD Ambient

If servicing the equipment requires system evacuation, then re-charge the system to the weight specified on the nameplate. Verify the system subcooling using the Subcooling Charging Table and, if necessary, adjust the charge using the procedure below.

1. For best results — the indoor temperature should be kept between 70°F to 80°F. Add system heat if needed.
2. Whenever charge is removed or added, the system must be operated for a minimum of 20 minutes to stabilize before accurate measurements can be made.
3. Measure Liquid Line Temperature and Refrigerant Pressure at service valved in the compressor compartment.
4. Locate your liquid line temperature in the left column of the table, and the intersecting liquid line pressure under the subcool value column, Add

refrigerant to raise the pressure to match the table, or remove refrigerant to lower the pressure. Again, wait 20 minutes for the system conditions to stabilize before adjusting charge again.

Note: System charge shall never be more than 110% or less than 90% of nameplate charge. If specified subcooling cannot be achieved within those charge bounds, contact your Field Service Representative.

5. When system is correctly charged, you can refer to System Pressure Curves to verify typical performance.

CHARGING BELOW 55°F

Evacuate system and weigh in nameplate charge or use factory charge. Correct subcooling may be verified when the temperature is above 55°F.

R-410A REFRIGERANT CHARGING CHART									
Refer to Service Facts or Installer's Guide for charging method									
LIQUID TEMP (°F)	DESIGN SUBCOOLING (°F)								
	6	8	9	10	11	12	13	14	16
	LIQUID GAGE PRESSURE (PSI)								
55	174	179	182	185	188	191	195	198	205
60	189	195	198	201	204	208	211	215	222
65	205	211	215	218	222	225	229	232	240
70	222	229	232	236	240	243	247	251	259
75	240	247	251	255	259	263	267	271	279
80	259	267	271	275	279	283	287	291	301
85	279	287	291	296	300	304	309	313	323
90	301	309	313	318	322	327	331	336	347
95	323	331	336	341	346	351	355	360	371
100	347	355	360	365	370	376	381	386	398
105	371	381	386	391	396	402	407	413	425
110	398	407	413	418	424	429	435	441	454
115	425	435	441	446	452	458	464	470	484
120	454	464	470	476	482	488	495	501	516
125	484	495	501	507	514	520	527	533	549

From Dwg. D154557P01

Wiring Diagrams

Figure 2. 4TCA4060A1 Models

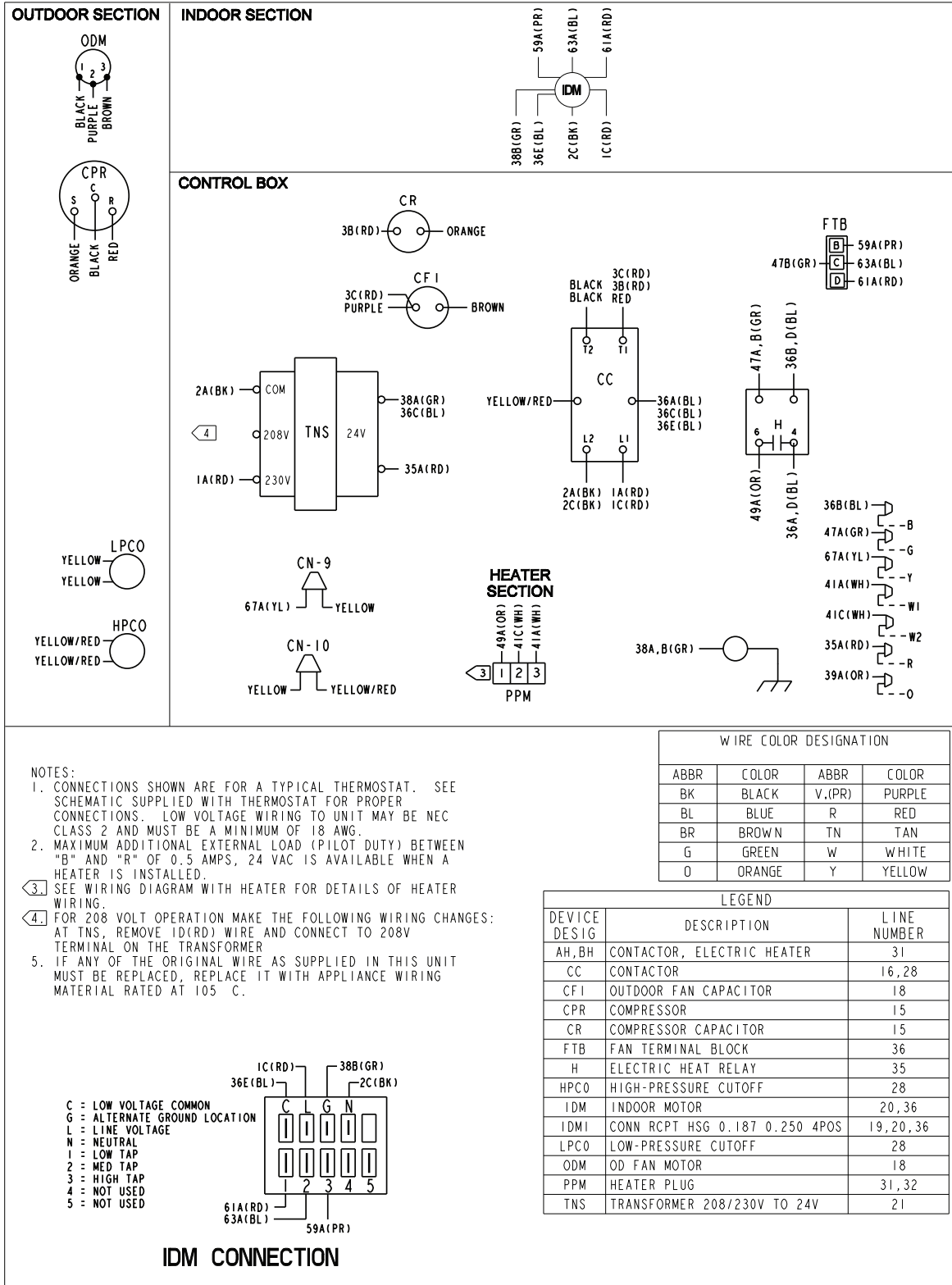
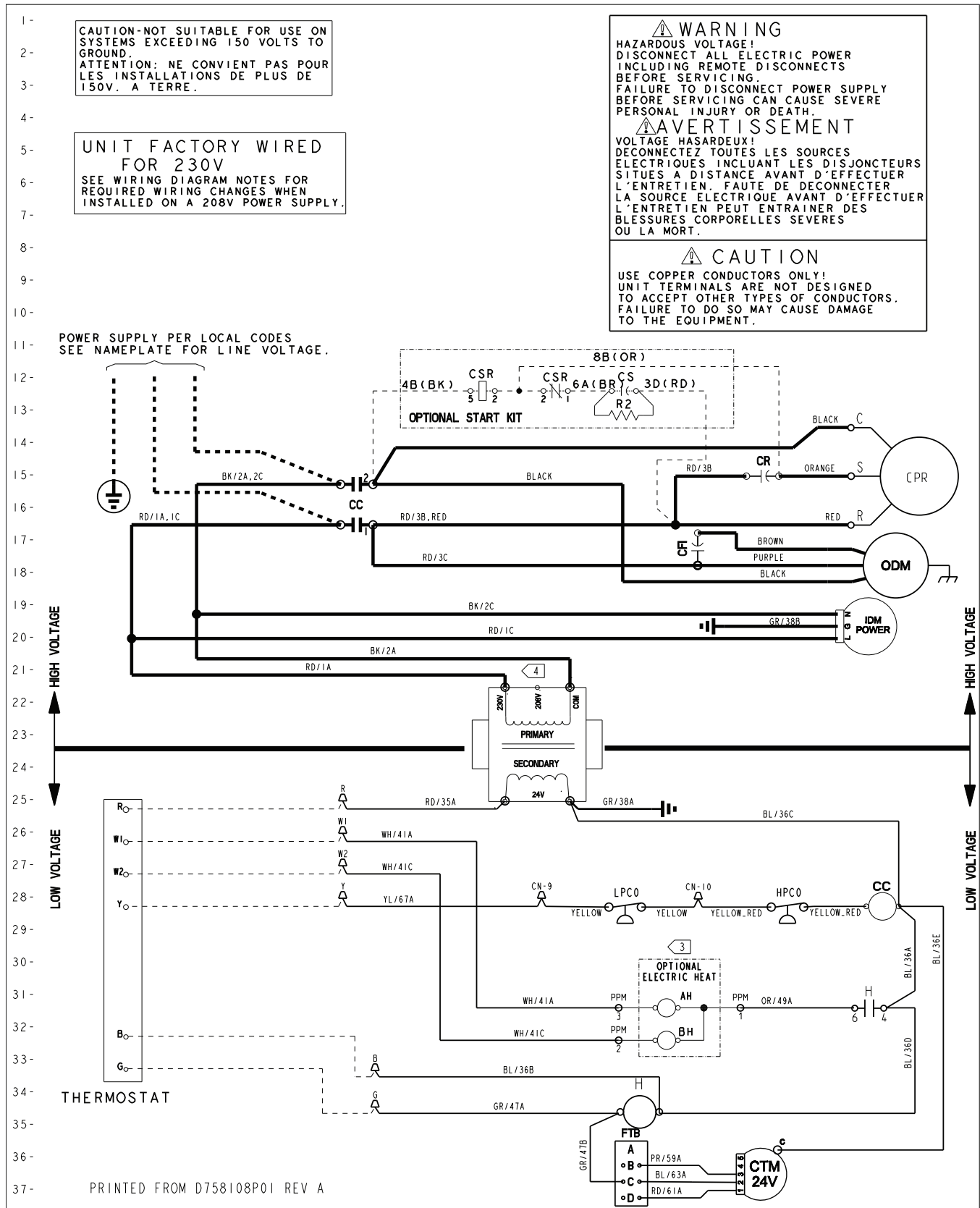
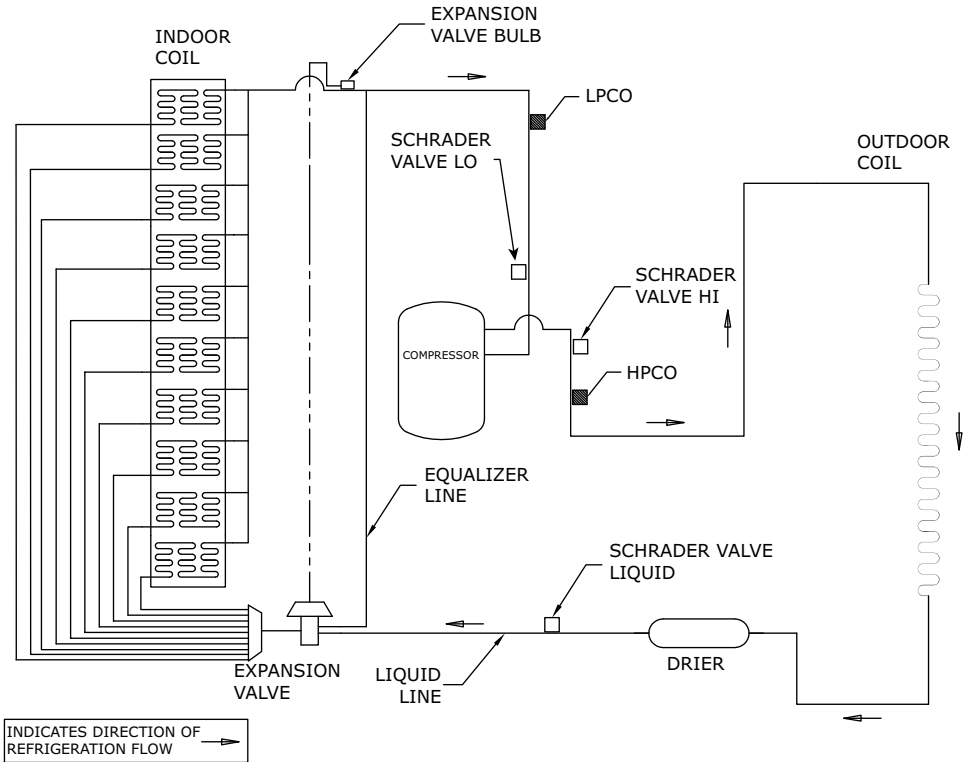

Figure 3. 4TCA4060A1 Models Page 2



Refrigerant Circuit



Troubleshooting Chart

P-PRIMARY CAUSES / S-SECONDARY CAUSES

SYSTEM FAULTS	Power Supply	High Voltage Wiring	Compr. IOL	Run Capacitor	Start capacitor	Start Relay	Contactors Contacts	Low Voltage Wiring	Control Transformer	Contactor Coil	Low Voltage Fuse	Stuck Compressor	Ineffecient Compressor	Refrigerant Undercharge	Refrigerant Overcharge	Excessive Evap. Load	Noncondensables	Restricted O.D. Airflow	O.D. Air Recirculation	TXV Stuck Open	Low Superheat	High Superheat	Restricted I.D. Airflow	Ref. Circuit Restrictions
REFRIGERANT CIRCUIT																								
Liquid Pressure too High															P		S	P	S					S
Liquid Pressure too Low													S	P						S		S		S
Suction Pressure too High													S		P	P				S	S			
Suction Pressure too Low														S								S	P	S
Liquid Refrigerant Floodback (TXV System)																				S	S		P	
I.D. Coil Frosting														P							S		P	S
Compressor Runs Inadequate or No Cooling													S	P		P	S	S	S			S	P	S
ELECTRICAL																								
Compressor & O.D. Fan Do Not Start	P	P					S	S	P	P	P													
Compressor will not Start but O.D. Fan Runs		P	S	P	P	P						S												
O.D. Fan will Not Start		P		P																				
Compressor Hums but will Not Start		P		P	P	P	S					S												
Compressor Cycles on IOL		P	S	P	P	P	S					P	S	P	S	S	S	S	S			S		S
I.D. Blower will not Start	P	S						S	P		P													

Important Product Information

Registering your products helps provide you with one of the strongest manufacturer limited warranties available. To register, go to the manufacturer's website or contact your dealer. You will need the serial number, model number, and installation date for each product being registered. Your dealer may have included these

on your invoice or can provide a list for you to use. Please take a few moments to record the following information to ensure your product registration process is quick and easy:

Packaged Unit Serial Number _____

Packaged Unit Model Number _____

Date of Installation _____

Dealer _____

Service Information

Call your installing dealer if the unit is inoperative. Before you call, always check the following to be sure service is required:

1. Be sure the main switch that supplies power to the unit is in the ON position.
2. Replace any burned-out fuses or reset circuit breakers.
3. Be sure the thermostat is properly set.

Service Phone _____

About Trane and American Standard Heating and Air Conditioning

Trane and American Standard create comfortable, energy efficient indoor environments for residential applications. For more information, please visit www.trane.com or www.americanstandardair.com.



The AHRI Certified mark indicates company participation in the AHRI Certification program. For verification of individual certified products, go to ahridirectory.org.

The manufacturer has a policy of continuous data improvement and it reserves the right to change design and specifications without notice. We are committed to using environmentally conscious print practices.